

ECU 15 C Technical Data Low Lift Pallet Truck

ECU 15 C



ECU 15 C Low Lift Pallet Truck

Powerful Energy Pack

In accordance with VDI guidelines 2198, this specification applies to the standard model only.
Alternative tyres, mast types, ancillary equipment, etc. could result in different values.



| Category | Item No. | Description | Unit | Value |
|----------------------|----------------|--|------------------------------|---|
| Distinguishing marks | 1.1 | Manufacturer | | STILL |
| | 1.2 | Manufacturer's type designation | | ECU 15 C |
| | 1.3 | Drive | | Electric |
| | 1.4 | Operation | | Walking |
| | 1.5 | Rated capacity/rated load | Q | kg 1500 |
| | 1.6 | Load centre distance | c | mm 600 |
| | 1.8 | Load distance, centre of drive axle to fork | x | mm 946 |
| | 1.9 | Wheel base | y | mm 1293 |
| | Weights | 2.1 | Service weight incl. battery | |
| 2.2 | | Axle loading, laden | drive end/load end | kg 510/1180 |
| 2.3 | | Axle loading, unladen | drive end/load end | kg 160/40 |
| Tyres/chassis | 3.1 | Tyres | | Polyurethane |
| | 3.2 | Tyre size | drive end | mm $\varnothing 200 \times 70$ ($\varnothing 230 \times 73$) ¹ |
| | 3.3 | Tyre size | load end | mm $\varnothing 80 \times 93$ ($\varnothing 80 \times 70$) ² |
| | 3.4 | Support castor size | | mm $\varnothing 80 \times 30$ |
| | 3.5 | Number of wheels (x = driven) | drive end/load end | 1x + 2/2 |
| | 3.6 | Tread | drive end/load end | b ₁₀ /b ₁₁ mm 410/380 |
| Dimensions | 4.4 | Lift | h ₃ | mm 115 |
| | 4.9 | Height drawbar in driving position | min./max. h ₁₄ | mm 800/1170 |
| | 4.15 | Fork height, lowered | h ₁₃ | mm 85 |
| | 4.19 | Overall length | l ₁ | mm 1660 |
| | 4.20 | Length to face of forks | l ₂ | mm 510 |
| | 4.21 | Overall width | b ₁ | mm 574 |
| | 4.22 | Fork dimensions | s/e/l | mm 48/160/1150 |
| | 4.25 | Distance between fork arms | b ₅ | mm 540 |
| | 4.32 | Ground clearance, centre of wheel base | m ₂ | mm 37 |
| | 4.34 | Working aisle width with pallets 800 x 1200 lengthways | A _{st} | mm 1880 |
| 4.35 | Turning radius | W _s | mm 1540 | |
| Performance data | 5.1 | Travel speed | laden/unladen | km/h 4.2/4.6 |
| | 5.2 | Lift speed | laden/unladen | m/s 0.03/0.053 |
| | 5.3 | Lowering speed | laden/unladen | m/s 0.049/0.036 |
| | 5.8 | Max. gradeability kB 5 | laden/unladen | % 4/10 |
| | 5.9 | Acceleration time | laden/unladen | 10.7/9.5 |
| | 5.10 | Service brake | | Electromagnetic |
| Electric engine | 6.1 | Drive motor, rating S2 = 60 min | | kW 0.45 |
| | 6.2 | Lift motor, rating S3 = 10 % | | kW 0.8 |
| | 6.3 | Battery according to DIN 43531 /35/36 A, B, C, no | | Nein |
| | 6.4 | Battery voltage/rated capacity K _s | | V/Ah 2x 12 V/85 |
| | 6.5 | Battery weight ±5% (depends on make) | | kg 52 |
| | 6.6 | Energy consumption according to VDI cycle | | kWh/h 0.39 |
| Misc. | 8.1 | Drive control | | DC control |
| | 8.4 | Sound pressure level at driver's ear | | dB(A) 69 |

¹ Option

² Tandem roller

ECU 15 C Low Lift Pallet Truck
Technical Drawings

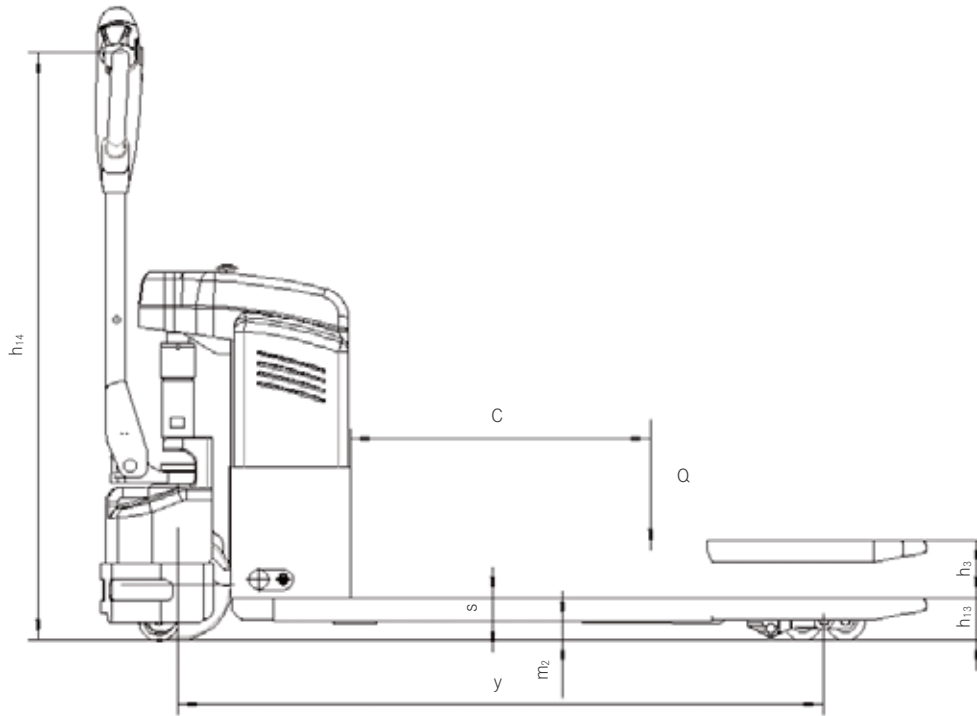

Side view

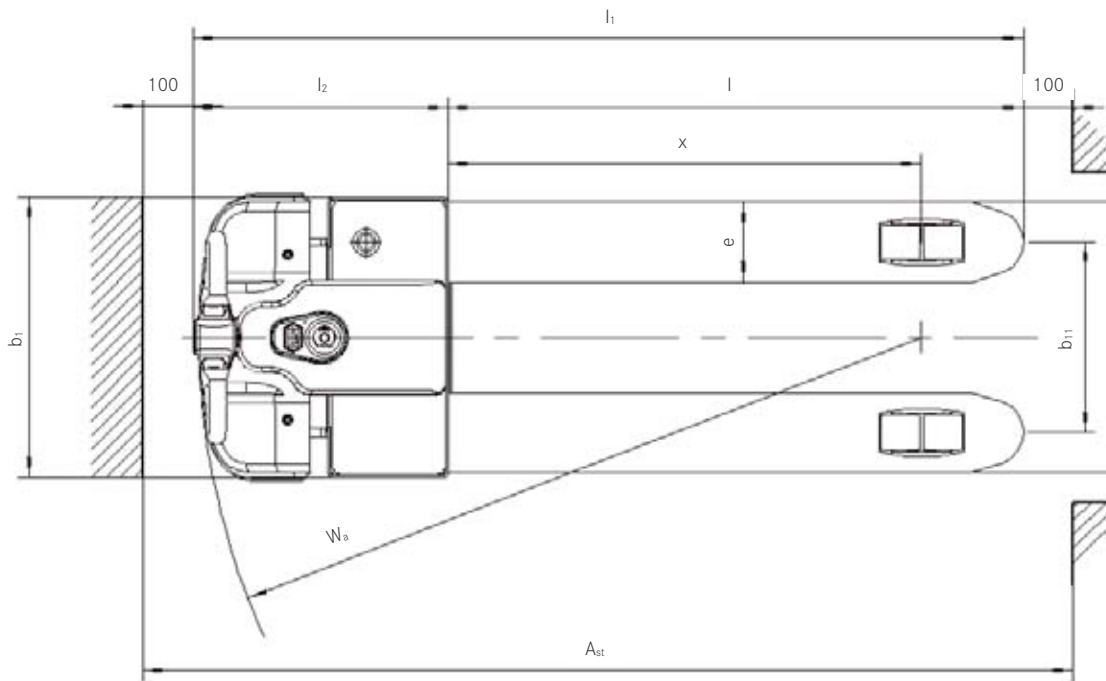

Top view

ECU 15 C Low Lift Pallet Truck
Detailed Photos



Best performance and view of the forks due to the structure's low height



Always informed: the display shows the charging level



No need to change grip: comfortable control with one hand only – either left or right



Safe on the road: the low chassis ensures maximum operating safety



Easy pick-up: the standard entry rollers make picking up pallets crosswise a cakewalk



Optimum traction and castor wheels for perfect stability

ECU 15 C Low Lift Pallet Truck
Powerful Energy Pack



Easy pallet pick-up: fast and precise work thanks to rounded fork tips (optionally available with tandem rollers)



ECU 15 C Low Lift Pallet Truck Powerful Energy Pack

Impressive goods handling: 1500 kg capacity and incredibly low service weight make it possible to take on any transportation task anywhere

Outstanding flexibility: compact size allows for operation even in the most confined spaces

Easy handling: moving goods electrically without strain and an on-board charger



Be it in industrial applications, retail or logistics – with its ECU 15 C, STILL offers more than just one good reason to dismiss hand pallet trucks into retirement. The low lift power pallet truck scores with a range of quality aspects: driving, lifting and lowering – all this is done electrically and without any physical force by the operator.

Compact and agile, this efficient warehouse helper moves any load weighing up to 1,5 tons – with the truck itself only weighing 200 kg – and that includes the battery. This makes the ECU 15 C an ideal truck for use on intermediate floors, in elevators or on the back of lorries, in particular if the lorry has a lift platform.

Thanks to the display, the operator will know the current charging level of the battery at all times. Even better: with a power consumption of only 0,39 kW per hour, the truck is not just very energy efficient, but with its on-board charger, the battery can be opportunity charged at any mains wall outlet. Availability and flexibility are the core aspects of the ECU 15 C. In operation, the pedestrian low lift pallet truck scores not only with its comfortable single-handed control which is suitable for left and right handed operators alike, but with its rounded fork tips with integrated entry rollers which make stacking pallets more efficient as well as more comfortable. Its robust chassis guarantees endurance in the long run, also if the application becomes a little tough.

Extensive Equipment

Power

- Full power: powerful, reliable and low-maintenance drive motor with 24 volt technology
- Transports goods with a total weight of up to 1500 kg
- Torsionally rigid frame construction guarantees durability and reliability

Precision

- Compact and mobile: works effortlessly in confined spaces and narrow aisles
- Precise load handling: the low cover provides optimum visibility of the fork tips
- Entry rollers for fast and easy crosswise pallet picking
- Precise transmission control for the benefit of the goods

Ergonomics

- Ergonomic and intuitive operation: driving, lifting and steering processes can be simultaneously controlled by left- or right-handed operators with just one hand and without having to change grip
- Ergonomically shaped tiller head for fatigue-free operation

Compactness

- Impressive reloading of pallets: compact size allows for quick and safe operation
- Compact and mobile: works quickly even in confined spaces and narrow aisles
- Fast and precise: rounded forks for easy threading into pallets

Safety

- Maximum user safety thanks to the deep-drawn frame
- Excellent driver safety due to automatic braking when tiller is released

Environmental Responsibility

- Very few noise emissions due to extremely quiet drive and lifting motor
- Over 95% of all materials used are recyclable
- Emission-free operation

ECU 15 C Low Lift Pallet Truck Equipment Variants



| | | ECU 15 C |
|----------------|--|----------|
| General | Can be adjusted ergonomically for maximum comfort and safety | ● |
| | Load capacity: 1.5 tonnes | ● |
| | Easy-grip tiller for left- and right-handed operators | ● |
| | Fork length: 540/1150 mm | ● |
| | Fork length: 520/1150 mm | ○ |
| | Fork length: 680/1150 mm | ○ |
| | Fork length: 520/1220 mm | ○ |
| | Fork length: 540/1220 mm | ○ |
| | Fork length: 680/1220 mm | ○ |
| Wheels | Drive wheel tyres, polyurethane | ● |
| | Drive wheel tyres, solid rubber | ○ |
| | Load roller tyres, polyurethane, single | ● |
| | Load roller tyres, polyurethane, tandem | ○ |
| Battery system | Built-in charger | ● |
| | Various types of mains plugs | ○ |
| | Built-in 85 Ah battery | ● |

● Standard ○ Optional



STILL



STILL Materials Handling Ltd
Aston Way
Leyland Preston
PR26 7UX
Tel.: +44 (0)845 603 6827

STILL Materials Handling Ltd
Jacks Way
Hill Barton
Business Park
Clyst St. Mary
Exeter
EX5 1FG
Tel.: +44 (0)345 603 6827

info@still.co.uk

For further information please visit:

www.still.co.uk



STILL is certified in the following areas: Quality management, occupational safety, environmental protection and energy management.



first in intralogistics